

---

**SIMULATION AND ANALYSIS OF FAULTS IN DISTRIBUTION NETWORK SYSTEM IN OGBOMOSO UNDERTAKING WITH DISTRIBUTION RELIABILITY INDICES**

**Koledowo Saliu Oyewale<sup>1</sup>, Abubakar Bawa<sup>2</sup> and Adenle Johnson Gbadebo<sup>3</sup>**

<sup>1</sup>Zuma Rock College of Health Technology,  
Suleja, Niger State, Nigeria.

<sup>2</sup>Transmission Company of Nigeria,  
National Control Centre, Osogbo,  
Osun State, Nigeria.

<sup>3</sup>Karume Institute of Science and Technology,  
Zanzibar.

**ABSTRACT**

Distribution network accounts for more than 90% of power service disruptions. This study present fault occurring on power distribution network using Ogbomoso Business hub as a case study consisting of four feeders namely: Takie, Oke-Ado, Owode and Gambari feeders. Simulation and Modeling were carried out using MATLAB/Simulink software package. Faults data are obtained for selected feeders using fault log book from the station under study. Analysis of fault is accomplished using MATLAB Software and associated with statistics measures (Distributed reliability indices). Reliability indices is therefore computed for each of the four feeders. The result shows that the Average Service Availability Index for Takie, Oke-Ado, Owode and Gambari feeders are 99.884%, 99.843%, 99.888% and 99.950% respectively.

**Keywords:** Faults, Simulation and analysis, Distribution network, reliability indices, IBEDC, MATLAB/Simulink.

---

**1. INTRODUCTION**

The grid electric power system consists of generation, Transmission, Sub-Transmission and Distribution.

Bulk power supply is from generation and Transmission while final means of electric power release to consumer are sub-Transmission and Distribution. The distribution delivers electric power to end-user [1]. Distribution system is the link between the utility system and the end-user, it is the most critical part of the power system and it is facing a lot of dangers that cause a power disruption to consumers, it can be stated that a great percentage of end-users' power outages are due to distribution network, it can also occur due to mal-function of the networks protection equipment [2].

The last two decades in Nigeria witnessed enormous investment in increasing the generation capacity and expanding the transmission lines. However, despite the significant function of Electric power distribution system in the delivery of electricity, the system has generally developed in an unplanned manner resulting in high technical and commercial losses as well as poor quality of power [3].

The power distribution network is characterized with a number of distribution substations located over a massive geographical area which is prone to faults caused by wind storms, lightning, rain, insulation breakdown, overloading and short circuits. Distribution lines experience faults more often than the faults experienced by other power system facilities [4].

In this study, the main focus is on analysis of faults that are associated with Takie, Oke Ado, Owode and Gambari feeders 11Kv distribution feeders controlled by Ibadan Electricity Distribution Company (IBEDC), Ogbomoso Business Unit in Oyo State as well as determining the reliability of the feeders in order to make useful suggestions on how to improve the service level of these feeders.

## **2. DISTRIBUTION SYSTEM FAULTS**

A fault on a power system is an anomalous condition that involves an electrical failure of power system equipment operating at one of the primary voltages within the system. Generally, two types of failure can occur. The first is an insulation failure results in a short-circuit fault and can occur as a result of overstretching and degradation of the insulation over time or due to a sudden overvoltage condition. The second is a failure that results in a termination of current flow or an open-circuit fault [5].

A fault in power system is described as any failure that cause interruptions of power supply [6]. Generally, faults occurring in power systems are traceable to natural events or by accidents where a phase establishes a connection with another phases, the ground or both. In some cases, faults may be as a result of deterioration in insulation, damages by wind or sabotage or vandalism by human [7]. Power system faults can be temporary or permanent. A temporary fault occurs when the actuation of protective system allows the circuit to be re-energized (fault clearing) after a reclosing operation. Examples of temporary fault are the insulation breakdown by the interaction between component agents (lightning strike, wind, transient tree contacts, etc.) during a short period of time. Permanent faults require repair or replacement of the damaged components. Examples of permanent faults include insulator damage by flashover, underground cable breakdown and surge arrester damage [8]. The fault phenomenon can affect system's reliability, security and energy quality [9]. Any reliable electric power system would serve consumers of the electric

power supply are exposed to unplanned outage on a regular basis which influence customer satisfaction [9]. The different types of faults that occur in a network can be classified in three major groups: short circuit faults; open circuited faults and simultaneous faults [10]. Simultaneous faults are a combination of two or more faults that occur at the same time. They may be of the same or different types and may occur at the same or at different locations [5].

**Short Circuit Faults**

Short circuit is an unbalance between phases or between phases and neutral. Short circuit occurs when the path of the load current is cut short because of breakdown of insulation [11]. The most dangerous phenomenon is normally the high current that occurs at a short circuit. The magnitude of fault current is dependent on what type of fault that occurs [12]. Short circuit is the unplanned or deliberate conductive connection through a relative low resistance or impedance between two or more points of a circuit which are usually at different potentials [10,13] There are ten different types of possible shunt faults types [14]. They are categorized in these four groups:

- (i) Single-phase-to-ground faults
- (ii) Two-phase-to-ground faults.
- (iii) Phase-to-phase faults
- (iv) Three-phase-to-ground faults

According to the faults statistics with reference to type of line faults occurrence, three-phase-to-ground faults account for between 70% and 80% while double line faults with or without earth having 15% and 5% involves all three phases [15,16].

**Single-phase-to-ground faults**

The following three types of Single-phase-to-ground faults as depicted in the figure 1 occurred in the power distribution [15]. They are:

- (a) Red-phase-to-ground fault
- (b) Yellow-phase-to-ground fault
- (c) Blue-phase-to-ground fault

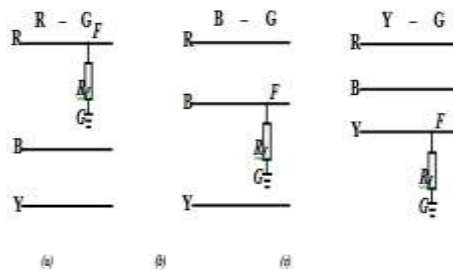


Figure no. 1 Single-phase-to-ground faults experienced on three-phase lines

### 3.2 Two-phase-to-ground faults

Three types of Two-phase-to-ground faults are defined in [17] as shown in figure 2. They are:

- (a) Phase B and phase Y-to-ground fault;
- (b) Phase R and phase B-to-ground fault;
- (c) Phase Y and phase R-to-ground fault.

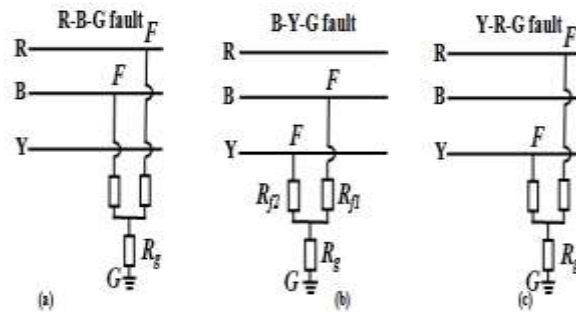


Figure no. 2: Two-phase-to-ground faults experienced on three-phase lines

### 3.3 Phase-to-phase faults

The three types of phase faults that can be experience on the three phase lines are as illustrated in the figure 3 are as follows [17]:

- (a) Phase R-to-phase-B fault
- (b) Phase R-to-phase-Y fault and
- (c) Phase B-to-phase-Y fault.

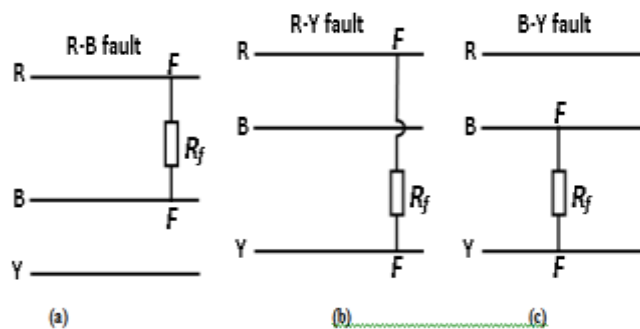


Figure no. 3: Phase-to-phase faults experienced on three-phase lines

### 3.4 Three-phase-to-ground fault

The three-phase faults the symmetrically affects the three phases of a three-phase circuit is the only balanced faults whereas all the other faults are unbalanced [5]. A three-phase short circuit faults also known as symmetrical or balanced faults infers that all three phases of the power system are

simultaneously short-circuited to each other through a direct or “bolted” connection. These faults can be with or without ground [12].

#### 4. DISTRIBUTION RELIABILITY

Reliability in engineering applications, as defined in the Authoritative Dictionary of IEEE Standard Terms (IEEE 100), is the probability that a device will function without failure over a period of specific period of time or amount of usage. In the case of electric power distribution, reliability concerns have come from customers who want uninterrupted continuous power supplied to their facilities at minimum cost [12].

A typical goal for an electric utility is to have an overall average of one interruption of not more than two hours' duration per customer year. Given 8760 hours in a non-leap year, this goal corresponds to an Average Service Availability Index (ASAI) greater than year. Given 8760 hours in a non-leap year, this goal corresponds to an Average Service Availability Index (ASAI) greater than or equal to  $8758 \text{ service hours} / 8760 \text{ hours} = 0.999772 = 99.977\%$  [8].

IEE Standard 1366-2003 entitled, IEEE Guide for Electric Power Distribution Reliability Indices, defined the following distribution reliability indices [18].

System Average Interruption Frequency Index (SAIFI):

$$\text{SAIFI} = \frac{\Sigma \text{Total Number of Customers Interrupted}}{\text{Total Number of Customers Served}}$$

System Average Interruption Duration Index (SAIDI):

$$\text{SAIDI} = \frac{\Sigma \text{Customer Interruption Duration}}{\text{Total Number of Customers Served}}$$

Customer Average Interruption Duration Index (CAIDI):

$$\begin{aligned} \text{CAIDI} &= \frac{\Sigma \text{Customer Interruption Duration}}{\text{Total Number of Customers Interrupted}} \\ &= \frac{\text{SAIDI}}{\text{SAIFI}} \end{aligned}$$

Average Service Availability Index (ASAI):

$$\text{ASAI} = \frac{\text{Customer Hour Service Availability}}{\text{Customers Hour Service Demand}}$$

**Table 1: Parameter used for Modelling Power Distribution Network (Source: IBEDC Ogbomoso)**

1	50MVA, 132/33Kv Power supply from Ilorin	Step down transformer at the Ilorin Transmission station	<input type="checkbox"/> Phase to phase voltage(v) =33kV <input type="checkbox"/> Phase angle of phase R =0° <input type="checkbox"/> Phase angle of phase Y = -120° <input type="checkbox"/> Phase angle of Phase B = 120° <input type="checkbox"/> Frequency = 50Hz <input type="checkbox"/> 3 phases short circuit level of base voltage (VA) = 100MVA <input type="checkbox"/> Base voltage (Vrms phase to phase) = 25kV <input type="checkbox"/> $x/r = 7$ <input type="checkbox"/> Generator type : Swing
2	Ogbomoso Town sub-Transmission station Feeders:	The main feeder serving part of the town (distribution network)	<input type="checkbox"/> Parameters on the feeder <input type="checkbox"/> Normal power: 15MVA Voltage ratio: 33/11kV, frequency: 50Hz <input type="checkbox"/> Winding 1 parameters $V_1$ ph-ph (Vrms) =33*10 <sup>3</sup> V $R_1$ (pu) = 0.014882 $L_1$ (pu) = 0. 49608 <input type="checkbox"/> Winding 2 parameters $V_2$ ph-ph (Vrms) = 11*10 <sup>3</sup> V $R_2$ (pu) = 0.43736 $L_2$ (pu) = 1.4579 <input type="checkbox"/> Magnetization resistance $R_m$ (pu) = 500 <input type="checkbox"/> Magnetization inductance $L_m$ (pu) = 500

3	Ogbomoso Township Feeders: <input type="checkbox"/> Takie <input type="checkbox"/> Oke-Ado <input type="checkbox"/> Owode <input type="checkbox"/> Gambari	Feeders serving part of the town (distribution network)	
4	Distributed Line parameters	The transmission line between the power source (NCC) to the various loads on distribution network(destination)	<input type="checkbox"/> Number of phase(N) = 3 <input type="checkbox"/> Frequency (f) = 50Hz <input type="checkbox"/> Resistance/unit length( $\Omega/\text{Km}$ ) = [N×N] matrix [0.01273 0.3864] <input type="checkbox"/> Inductance/ unit length(H/km) = [N×N] matrix [0.9337 ×10 <sup>-3</sup> 4.1264×2×10 <sup>3</sup> ] <input type="checkbox"/> Conductance /Unit length (f/km) [N×N] matrix [12.74 × 10 <sup>9</sup> 7.751×10 9] <input type="checkbox"/> Length of line(km) = 50, 1, 0.8, 0.2 & 0.1 respectively
5	V.I measurement block	Ideal for 3 phase voltage and current measurements	<input type="checkbox"/> Voltage measurements = phase to ground <input type="checkbox"/> Base power(VA) = 100MVA <input type="checkbox"/> Normal voltage measurement(pu) (Vrms phase to phase) =500MV
6	Distribution transformer (Typical Substation)	The transformer step down the voltage to consumable voltage (415V)	<input type="checkbox"/> Note; All measurement in (pu) <input type="checkbox"/> Normal Power (VA) = 5×10 <sup>3</sup> <input type="checkbox"/> Frequency: 50Hz <input type="checkbox"/> Winding 1 parameter

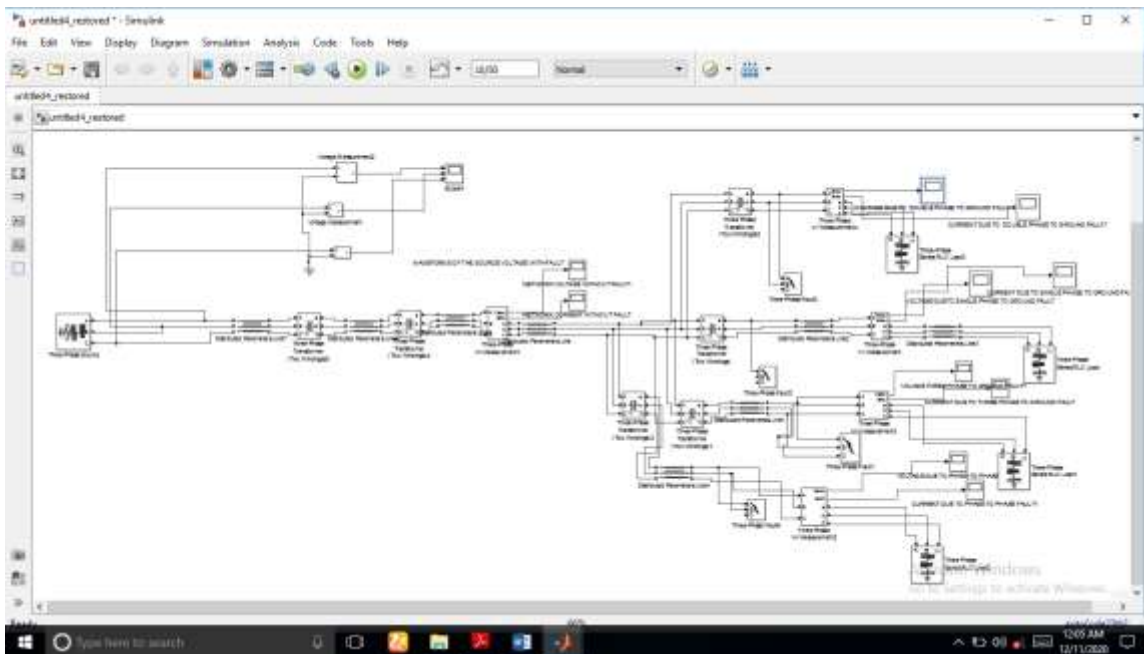
			$V_1$ (ph-ph) $V_{rms} = 11kV$ $R_1(pu) = 0.51529$ $L_1 (pu) = 1.9843$ <input type="checkbox"/> Winding 2 parameters $V_2$ (ph-ph) $V_{rms} = 0.415kV$ $R_2(pu) = 0.0984021$ $L_2(pu) = 3.2801$ <input type="checkbox"/> Magnetization resistance $R_m(pu) = 500$ <input type="checkbox"/> Magnetization inductance $L_m(pu) = 500$
7	Phase to Phase Fault on Owode feeder	The block model represents the fault with phase to phase fault characteristics	<input type="checkbox"/> Fault resistance( $\Omega$ ) = 0.001 <input type="checkbox"/> Transform status [1 0] <input type="checkbox"/> Translation [1/60 3/60] <input type="checkbox"/> Snubber Resistance [ $\Omega$ ] = $1 \times 10^6$
	Two phase to ground fault on Oke-Ado feeder	The block model represents the fault with two phase to ground characteristic	<input type="checkbox"/> Fault resistance( $\Omega$ ) = 0.001 <input type="checkbox"/> Transform status [1 0] <input type="checkbox"/> Translation [1/60 3/60] <input type="checkbox"/> Snubber Resistance [ $\Omega$ ] = $1 \times 10^6$
8	Single Phase with ground fault on Takie feeder	Fault model with single phase to ground fault characteristic	<input type="checkbox"/> Fault resistance( $\Omega$ ) = 0.001 <input type="checkbox"/> Transform status [1 0] <input type="checkbox"/> Translation [1/60 3/60] <input type="checkbox"/> Snubber Resistance [ $\Omega$ ] = $1 \times 10^6$ <input type="checkbox"/> Snubber capacitance $C_p$ (farad) = inf



10	Three Phase to ground fault on Gambari feeder	Three phase fault characteristics	<input type="checkbox"/> Fault resistance( $\Omega$ ) = 0.001 <input type="checkbox"/> Transform status [1 0] <input type="checkbox"/> Translation [1/60 3/60] <input type="checkbox"/> Snubber Resistance [ $\Omega$ ] = $1 \times 10^6$ <input type="checkbox"/> Snubber capacitance Cp (farad) = inf .
11	Typical Load on the Network	The model represents the load on each of the substation. It represents the resistance, capacitive and inductive load on the network	<input type="checkbox"/> Normal voltage ph to ph = 11kV <input type="checkbox"/> Normal frequency = 50Hz <input type="checkbox"/> Active power $10 \times 10^6$ W <input type="checkbox"/> Inductive reactive power $2.5 \times 10^6$ Var. <input type="checkbox"/> Capacitive reactive power = 100 Var <input type="checkbox"/> Type of load = constant z

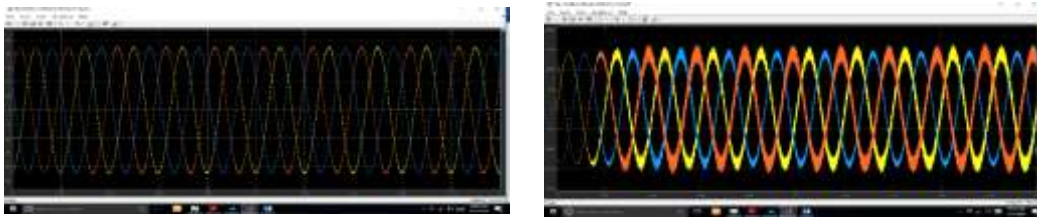
**5. Simulation of faults into Distribution network**

Simulation was done in MATLAB/Simulink environment which shows the distribution system of 11kV containing four feeders as depicted in figure 4.



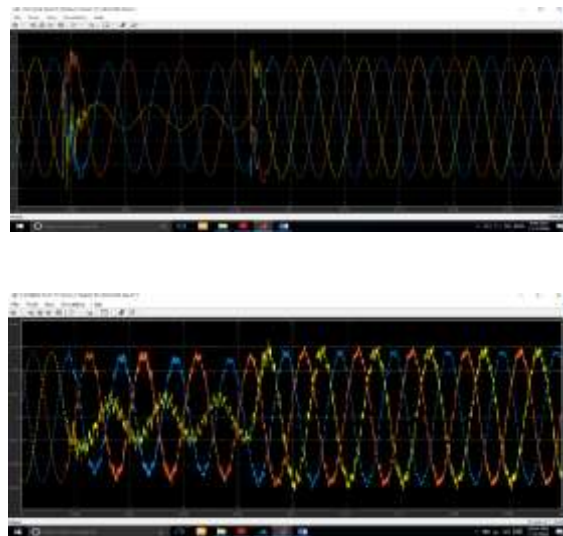
**Figure 4: Simulation of Faults into the Distribution Network**

## 6. RESULT AND DISCUSSION



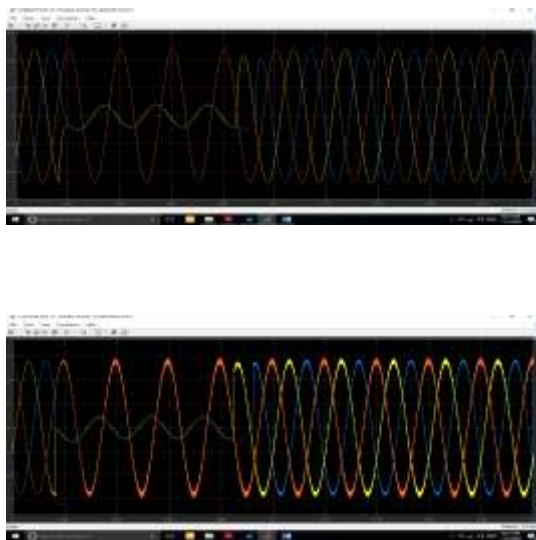
**Figure 5: Current and Voltage Waveform result from substation before fault phases**

From the figure 5, it can be deduced that both waveforms were not perfect and smooth especially the voltage waveform. It can be detected that this distortion is an indication that the power quality from the source have been distorted as a result of disturbance due to the combination of different types of line faults on the system.

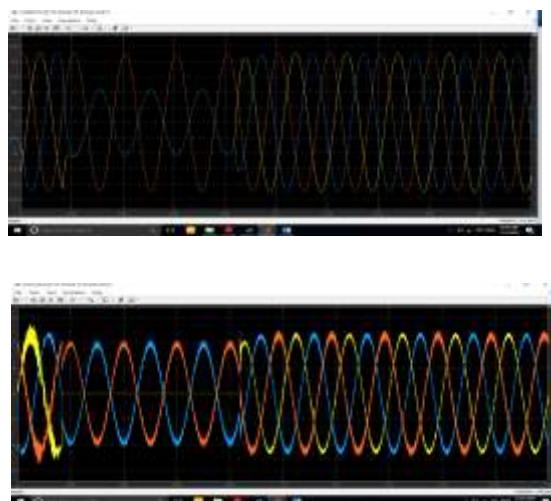


**Figure 6: Current and Voltage Waveforms result from modeled phase-to-ground fault**

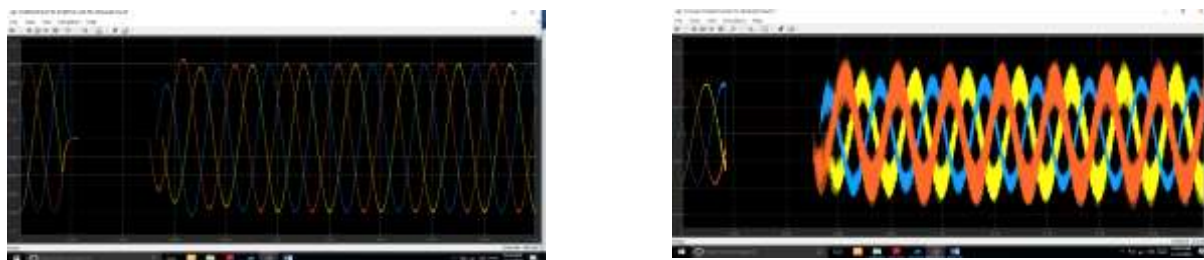
It can be seen from the Figure 6 that this type of fault leads to disruption in one of the three phases. Although, the effect is not so adverse as shown in Figure 6 but has some effect on the other phases. The fault on the yellow phase resulted into some disturbances on other phases. The fault is clear off and waveform become perfect as obtained in the simulation result.



**Figure 7: Current and Voltage Waveforms result from modeled Two-phase-to-ground fault**



**Figure 8: Current and Voltage Waveforms result from modeled Phase-to-phase fault**



**Figure 9: Current and Voltage waveforms result from modeled Three-phase-ground fault**

### Single Phase to Ground Fault

From data obtained from IBEDC and waveforms gotten from simulation:

1 division = 0.084s

1 complete cycle = 10 divisions

1 cycle = 0.084\*10 = 0.84

Duration of interruption, 60\*0.84 = 50.4

No of customer served = 56,862

No of customer interrupted = 11,252

Sum of customer interrupted Duration,

$$50.4 * 11,252 = 576100.8$$

$$\begin{aligned} \text{SAIFI} &= \frac{\sum \text{Total No of Customers interrupted}}{\text{Total No of customer served}} \\ &= \frac{11252}{56862} \\ &= 0.19 \text{ interruption/year} \end{aligned}$$

$$\begin{aligned} \text{SAIDI} &= \frac{\sum \text{Customers interruption Duration}}{\text{Total No of customer served}} \\ &= \frac{576100.8}{56862} \\ &= 10.13 \text{ minutes/year} \end{aligned}$$

$$\begin{aligned} \text{CAIDI} &= \frac{\sum \text{Customers interruption Duration}}{\text{Total No of customer interrupted}} \\ &= \frac{10.13}{0.19} \\ &= 53.32 \text{ minutes/year} \end{aligned}$$

$$\begin{aligned} \text{ASAI} &= \frac{\sum \text{Customers Hour service Availability}}{\text{Customer Hour Service Demand}} \\ &= \frac{(8760 * 56862) - 576100.8}{8760 * 56862} \\ &= 0.99884 \\ &= 99.884\% \end{aligned}$$

### Phase-to-Phase Fault

Duration of interruption, 60\*0.085\*10 = 51

No of Customer served = 56,862

No of customer interrupted = 15,315

Sum of customer interrupted Duration,

$$51 * 15,315 = 781065$$

$$\begin{aligned} \text{SAIFI} &= \frac{15315}{56862} \\ &= 0.27 \text{ interruption/year} \end{aligned}$$

$$\text{SAIDI} = \frac{781065}{56862}$$

$$\begin{aligned} &= 13.74 \text{ minutes/year} \\ \text{CAIDI} &= \frac{13.74}{0.27} \\ &= 50.89 \text{ minutes/year} \\ \text{ASAI} &= \frac{(8760 \times 56862) - 7810652}{8760 \times 56862} \\ &= 0.99843 \\ &= 99.843\% \end{aligned}$$

### Two-Phase-to-Ground Fault

Duration of interruption,  $60 \times 0.044 \times 10 = 26.4$

No of Customer served = 56,862

No of customer interrupted = 21,138

Sum of customer interrupted duration,

$$26.4 \times 21138 = 558043.2$$

$$\begin{aligned} \text{SAIFI} &= \frac{21138}{56862} \\ &= 0.37 \text{ interruption/year} \end{aligned}$$

$$\begin{aligned} \text{SAIDI} &= \frac{558043.2}{56862} \\ &= 9.81 \text{ minutes/year} \end{aligned}$$

$$\begin{aligned} \text{CAIDI} &= \frac{9.81}{0.37} \\ &= 26.51 \text{ minutes/year} \end{aligned}$$

$$\begin{aligned} \text{ASAI} &= \frac{(8760 \times 56862) - 558043.2}{8760 \times 56862} \\ &= 0.99888 \\ &= 99.888\% \end{aligned}$$

### Three Phase-to-Ground Fault

Duration of interruption,  $60 \times 0.045 \times 10 = 27$

No of Customer served = 56,862

No of customer interrupted = 9,157

Sum of customer interrupted duration,

$$27 \times 9157 = 247,239$$

$$\begin{aligned} \text{SAIFI} &= \frac{9157}{56862} \\ &= 0.16 \text{ interruption/year} \end{aligned}$$

$$\begin{aligned} \text{SAIDI} &= \frac{247239}{56862} \\ &= 4.35 \text{ minutes/year} \end{aligned}$$

$$\begin{aligned} \text{CAIDI} &= \frac{4.35}{0.16} \\ &= 27.19 \text{ minutes/year} \end{aligned}$$

$$\begin{aligned} \text{ASAI} &= \frac{(8760 \times 56862) - 247239}{8760 \times 56862} \end{aligned}$$

$$= 0.99950$$
$$= 99.950\%$$

## 6. CONCLUSION

In this research paper, simulation methodology of fault integration into distribution network was presented using MATLAB/Simulink. Results obtained offer insight into patterns of faults occurring on each feeder in Ogbomoso Business unit of Ibadan Electricity Distribution Company (IBEDC). This study was carried out to show the outline of individual feeder fault occurrence of fault and maintenance policy so as to improve customer satisfaction which is the ultimate goal of any distribution company.

## REFERENCES

- [1] A. Bawa, U. Muhammed, E. F. Shuaibu and S. O. Koledowo, "Optimal Sizing and Siting of Distribution Generation for Power Quality Improvement of Distribution Network in Niger State, Nigeria" European Journal of Engineering Research and Science (EJERS), Vol. 4, No 10, pp18-23, Oct. 2019.
- [2] L. K. Kumpulainen and K. T. Kauhaniemi, "Analysis of the impact of distributed generation on automatic reclosing," in IEEE PES Power systems conference and Exposition, Vol. 1, pp 603-608, Oct. 2019.
- [3] M. H. J. Bollen "Understanding power quality problems, Voltage sags and interruptions," New Jersey, USA, IEEE Press, p 541, 1999.
- [4] E. A. Ogunjor, P. Otasowie and P. A. Kuale "Fault Analysis of Electric Power Distribution in Benin City," Journal of Electrical and Electronic Engineering, Vol. 10, pp 27-34, 2006.
- [5] T. Nasser "Power System Modelling and Fault Analysis," 2<sup>nd</sup> ed., Academic Press, Elsevier, 2019.
- [6] A. D. Filomena, M. Ressenner, R. H. Salim and A. S. Bretas "Distribution System Faults Analysis Considering Fault Resistance Estimation," Electrical Power and Energy Systems, Vol. 33, pp 1326-1335, 2011.
- [7] S. Jorge, "Analysis of Power under Fault Conditions," M.Sc. Dissertation, Electrical and Electronic Engineering, California State University, Sacramento, 2011.
- [8] O. A. Quiroga, J. Melendez, S. Herraiz and J. Sanchez, "Sequence Pattern Discovery of Events Caused by Ground Fault Trip in Power Distribution Systems," 18<sup>th</sup> Mediterranean Conference on control and Automation, MED' 10, Marrakech, 2010.
- [9] D. A. Shalangawa, D. Y. Shinggu and T. Jonathan. "An Analysis of Electric Power Faults in Mubi Undertaking Station, Adamawa State, Nigeria," Pacific Journal of Science and Technology, Vol. 10, No 2, pp 508-513, 2009.
- [10] H. Boknam, C. Shin, S. Kwon and S. Park. "Power Quality monitoring on Distribution network using distribution automation system" 19<sup>th</sup> International Conference on Electricity Distribution, Vienna, 2007.
- [11] P. M. Anderson, "Analysis of faulted Power System," IEEE Press Power System Engineering Series, New York, 1995.
- [12] P. Christopher, "Protection of Electrical Networks," Antony Rowe Ltd, Chippenham, Wiltshire, pp 77-111, 2006.
- [13] IEEE Trans Power Delivery, "Outage Detection System ITU (2006)," Internet Report 2006 Digital Life, pp 865-867, 2007.
- [14] S. H. Horowitz and A. G. Phadke, "Protective System Relaying," Research Studies Press Ltd, Taunton, England, 1992.
- [15] R. Das, "Determining the Location of Faults in Distribution Systems," Ph.D Thesis, College of

Graduate Studies and Research, University of Saskatchewan, Saskatchewan, 1998.

[16] J. J. Grainger, S. H. Lee and A. A. El-Kib, “*Design of a real-time control scheme for capacitive compensation of Distribution feeders,*” IEEE Trans on Power Apparatus and Systems, Vol. 101, pp 1012-1020, 1981.

[17] R. Das, M. S. Sachdev and T. S. Shidhu. “*A Fault Locator for Radial Sub-transmission and Distribution Lines,*” Proceedings of IEEE PES SM Seattle, Washington, Vol. 1, pp 443-448, 2000.

[18] J. D. Glover, S. S. Mulukuta and J. O. Thomas, “*Power System Analysis and Design,*” Fifth Edition, Cengage Learning, USA, 2012.